

Sensitive, Tough, and Solid-State Reliable

SensaTank *Marine 100* is everything you want in a sea-going partner. The SensaTank liquid-level monitoring panel is a new application of proven components from TouchSensor Technologies. It uses patented “Field-Effect” sensing technology to measure and display the levels of three non-fuel holding tanks.

SensaTank *Marine 100* is the most reliable and hassle-free monitoring system available because it eliminates the parts that cause other systems to fail:

- NO shafts or seals to leak
- NO moving parts to jam
- NO exposure to corrosive liquid
- NO probes to become clogged or coated
- And NO effect from temperature, humidity or vibration

Measurement Without Immersion



LevelGuard’s “Field-Effect” sensing technology produces an invisible, low-power electric field that can detect the presence of fluid directly through non-conductive tank walls. Sensors are sealed, have no moving parts, and are designed to be mounted “Outside” the holding tank.

TouchCell Display Panel uses “Field-Effect”

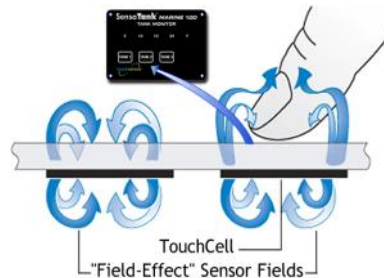

“Field-Effect” is more than just reliable fluid detection – it’s also the world’s most dependable touch-input technology, with nearly 200 million TouchCells™ proven in commercial applications.

- With TouchCell input, there are no mechanical contacts to wear out or fail.
- Touch any tank button – the panel instantly displays the status of the selected tank in a scale of bright yellow LEDs.
- The SensaTank *Marine 100* panel is compact, efficient, and has the look of a well-run ship. Instead of individual gauges, it displays status of three tanks through a single interface panel.
- Reads only on demand so there's no continuous current draw.

SensaTank *Marine 100* is the Future of Onboard Measurement.

The decorative LED panel shines bright with style, reliability, and accuracy. Even better – it’s competitively priced and more durable than predecessor technology. Specify SensaTank... and get onboard with the future.

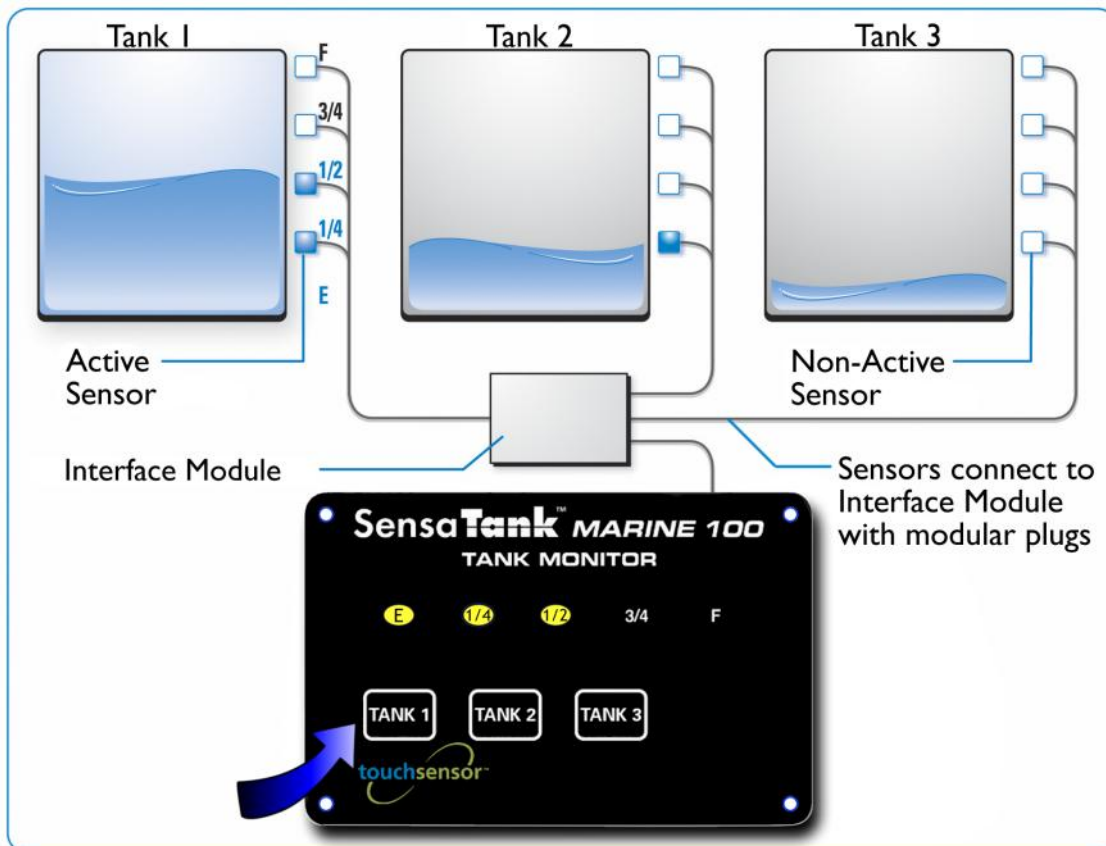

Specifications

- SensaTank™ *Marine 100*™ kit contains Display Panel, Interface Module, and LevelGuard™ Sensors for three plastic tanks. NOT for use on fiberglass or metal tanks.
- Tank wall thickness can be up to 10mm (.394"). Tanks can be any volume.
- Includes a concealed Interface Module and modular connection system (for modular connection to LevelGuard Sensors).
- LevelGuard Sensors attach to tanks with aggressive foam-tape adhesive for a long-life assembly.
- Tank surfaces must be cleaned with 90% isopropyl alcohol before adhesive application of sensor (do not use rubbing alcohol or acetone).

- The SensaTank *Marine 100* system is NOT compatible with existing wiring harnesses. It should only be installed as a stand-alone fluid monitoring system.
- The SensaTank *Marine 100* system can work with two separate Display Panels (purchase additional Display Panel separately). To attach, connect an additional CAT-5 Ethernet cable from the Remote Panel terminal (on the Interface Module) to the connector on back of the Display Panel. See illustration below.
- Powered by one 12V connection at the Display Panel.
- Draws less than 0.001-amp when no keys pressed. Maximum allowed current draw is 1-amp.

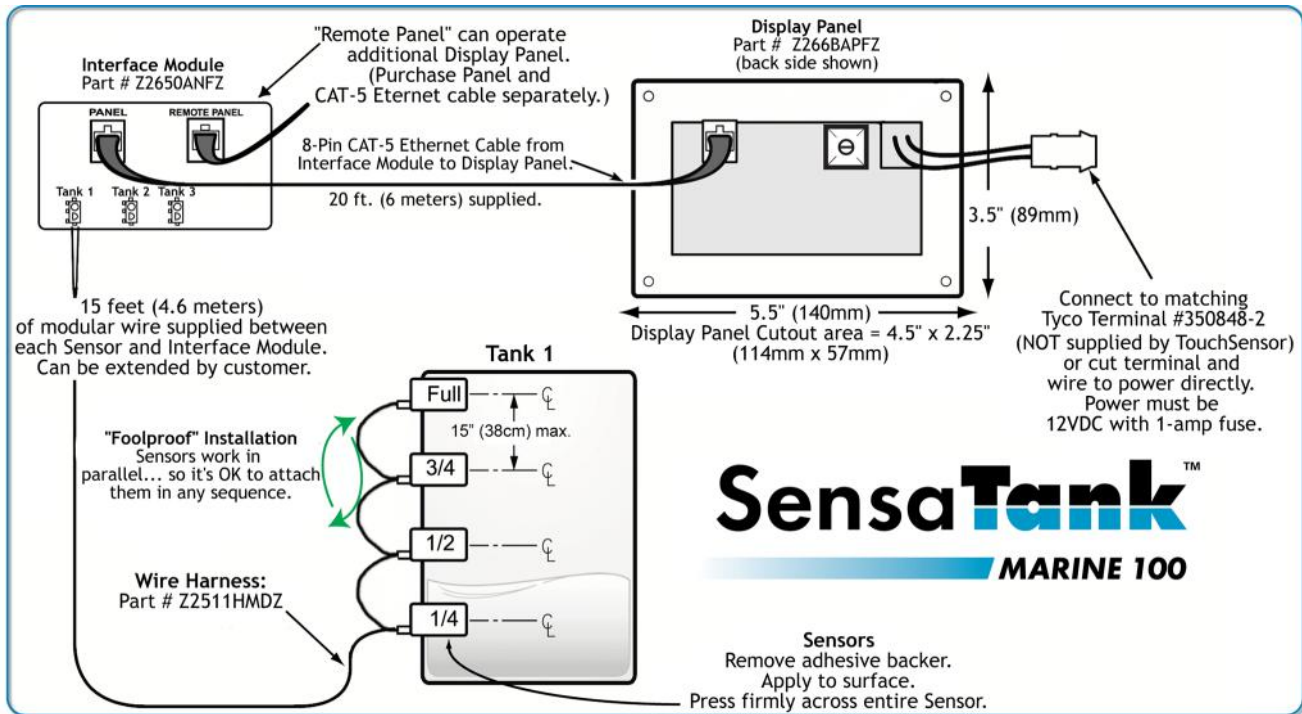

Order online at www.LevelGuardProducts.com

Model Numbers	Website SKU	Description
Z266MAKT	ST-MAR-100	Complete Kit: SensaTank <i>Marine 100</i> Display Panel, Interface Module, 3 Wire Harnesses
Z2650ANFZ	RV100MODUL	Interface Module
Z266BAPFZ	M100DISP	Display Panel
Z2511HMDZ	RVHARNESS	Wire Harness (One required per tank)

Contact Sales Department at (877) 342-3261

levelguard@touchsensor.com

www.LevelGuardProducts.com

LevelGuard, SensaTank *Marine 100*, and TouchCell are trademarks of TouchSensor Technologies, LLC.
203 North Gables Blvd.
Wheaton, IL 60187

Protected by U.S. Patent Numbers 5594222, 6310611, 7373817.
ISO 9001:2008

Proud Members of RVIA (Recreation Vehicle Industry Association)



© 2010, TouchSensor Technologies, LLC
Spc-SensaTank *Marine*, Rev. D, 2010/07